

# Join Cell for the G150 Aircraft

Samuel O. Smith and Dr. Peter B. Zieve  
Electroimpact Inc.

Michael Gurievsky  
Israel Aircraft Industries Ltd.

Copyright © 2006 SAE International

## ABSTRACT

A simple, open, post and index system is used for final alignment and joining of the fuselage and wings of a new passenger business jet. 19 manually actuated axes precisely move the wings, forward, and rear fuselage sections into position. Movement is accomplished with industrial jacking screws and positions recorded with precision linear potentiometers. Wing sweep, angle of attack, and dihedral are monitored and controlled. The axes positions are downloaded to data files for verification and data archiving. The Gulfstream G150 Join Cell's open architecture enhances access to fasten the main aircraft structure while maintaining flight critical geometry.

## INTRODUCTION

The Gulfstream G150 is an all new, high-speed, mid-size, business jet. With program launch in 2003, the structure assembly and all system installations are done in Israel by Israel Aircraft Industries (IAI). IAI has built a number of business aircraft, including the Westwind series, Gulfstream G100 (Astra) series, and the Gulfstream G200 (Galaxy) currently in production. The G150 fuselage structure is largely made out of aluminum alloy.

Design and build of the assembly fixtures for the new G150 aircraft was subcontracted to Electroimpact. In addition to the fixed tooling of this aircraft, IAI and Electroimpact conceived and built a simple, unique Join Cell for the final wing and fuselage join of the whole airframe. See Figures 1, 2, and 3.

Traditionally, the aircraft structure joining operations are the most complex and therefore the longest in terms of the required labor hours. In order to reduce assembly cost, large commercial airframes are joined using expensive automatic laser alignment systems. These systems are sensitive to the assembly floor environment and are complicated for production personnel. Automatic laser alignment system's cost exceeds many hundreds

of thousands of dollars. The described manual Join Cell is perfectly suits mid-size business jet assembly needs.

The main purpose of the Join Cell is to provide accurate positioning for the wings and fuselage sections. See Figure 4 for the axes positioning capabilities of the join cell. Other important aspects of the join cell include

1. An "open" post-type architecture to facilitate access to the wing fuselage joints for drilling and fastening.
2. Intuitive, jack-screw-assisted manual movement of the aircraft sections.
3. 19 axes of jack-screw assisted motion for moving fuselage and wing sections into the correct positions.
4. Accurate measurement and adjustment of the wing tips for sweep, angle of attack, and dihedral.
5. Accurate location of the rear engine mounts
6. The ability for gross movement (1 meter) of wings and fuselage sections apart to assist cleaning and deburring.
7. The ability to easily move the wings and fuselage sections back to a previously established position.
8. An electronic method of verifying and recording each axes join positions.
9. Process improvement by verifying and reviewing final join positions aircraft-to-aircraft.

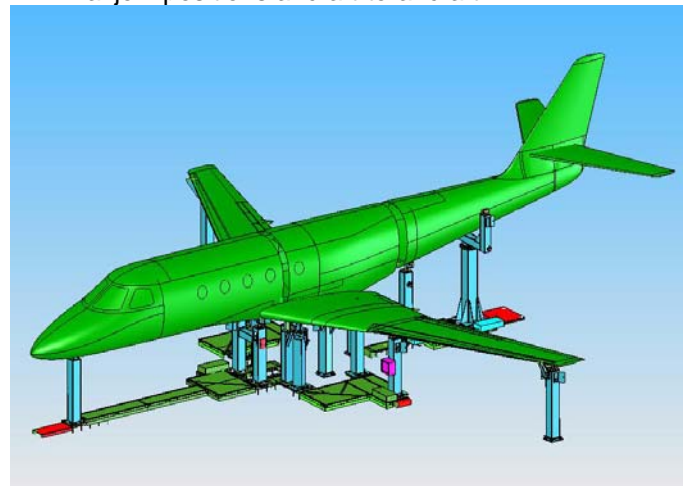

Figure 1. G150 Join Cell Overall Model



Figure 2. G150 Join Cell overall side photograph



Figure 3. G150 Join Cell overall front photograph

### G150 JOIN CELL DESCRIPTION

The join cell attaches the following major subassemblies of the G150:

- Fixed, center fuselage section. This section consists of the Carry Through Structure (CTS), over-wing section of the passenger cabin and the integral fuel tank structure.
- Forward fuselage section including the forward passenger cabin, cockpit and nose landing gear.
- Rear fuselage section including engine mounts
- Left and right wings

The center fuselage section is securely mounted and fixed through the CTS in the jig. See Figures 4 and 5. The other four assemblies are mounted on moving jig tooling and maneuvered into place with hand cranked, precision, screw actuators.



Figure 4. Center Fuselage Section loading into join cell, front view



Figure 5. Center Fuselage Section loaded in join cell, side view

### METHOD OF JOINING

IAI's process for final join of the G150 follows. First the Center Section is fixed to the four posts via the CTS in the middle of the join cell. A crane delivers the fore and aft fuselage and the port and starboard wing to the join cell. These are placed on their respective post and cradles 850 mm (33.5 inch) away from the Center Section. Operators push the subassemblies toward the Center Section then manipulate the jacking screws for the correct fit and position of all components. Electronic measurements are made and verified for the wing and engine mount positions. Production personnel manually drill all holes between the 5 aircraft subassemblies.

The wings and the fore and aft fuselage are then retracted (850 mm) from the Center Section. All holes and surfaces are deburred and cleaned as needed. Sealant is applied where specified, and then the aircraft subassemblies are manually jacked to the exact prior joining positions. Final fastening of the fuselage splices and the wing to CTS joint occurs. Data on all axes positions is recorded as desired through the join process and at the final join positions. All fixture pins are removed. A crane moves the one-piece G150 airframe to the next position in the assembly line.

#### Overall axes descriptions

There are 25 moveable actuators total. Starboard and port wings each have 5 positional actuators plus 3 measurements near each wing tip. Four actuators position the forward fuselage; the aft fuselage has 5 actuators. There is electronic position sensing on every actuated axis. Please see Figure 6.

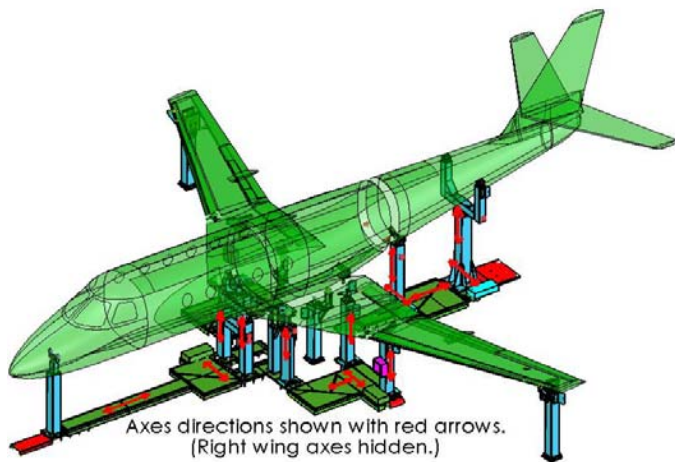

Figure 6. Join Cell model - axes of motion

Each of the moving fuselage or wing subassemblies is indexed on posts mounted on “rafts” or tooling carriages. The rafts are bolted to the concrete floor and leveled. Each raft easily moves on linear roller bearings with precision screw jacks. See the description below.

Posts with tooling components for locating aircraft features (landing gear axes, engine mounts, wing spars) are mounted to each raft. Aircraft indexes are atop each post. The relatively open arrangement of the posts allows mechanics to move the aircraft assemblies into position and then fasten the joints to the center fuselage section.

The forward fuselage section is manipulated fore/aft, up and down. See Figure 7. The rear most part of the fore fuselage section has two independent axes to control the “roll” of that assembly where it attaches to the center fuselage.

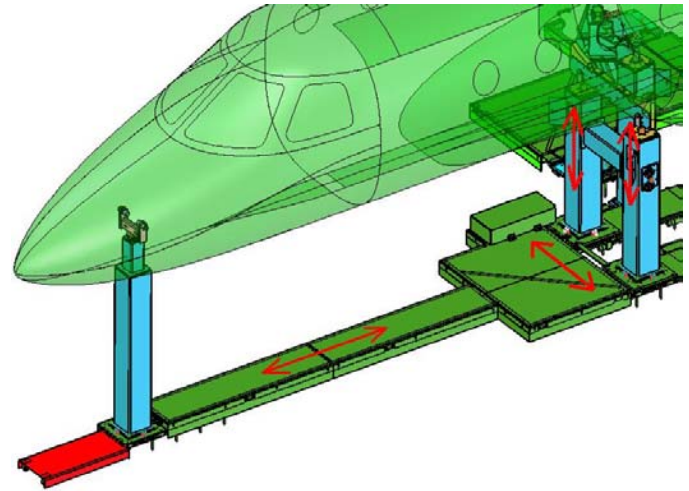

Figure 7. Fore fuselage axes motion detail

The aft fuselage is manipulated fore/aft. Please see Figure 8. A post under the front of the aft fuselage manipulates both inboard/outboard and up/down (water line.) An independent post attached at the engine mounts at the rear of the aft fuselage manipulates the engine mounts both inboard/outboard and up/down (water line.) A passive bearing allows engine mount rotation in the horizontal plane parallel to the rear fuselage.

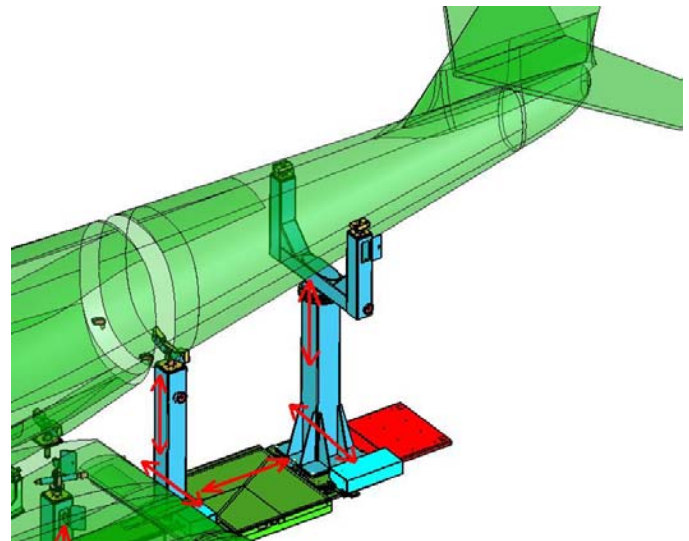

Figure 8. Aft fuselage axes motion detail

The wings independently move inboard/outboard and fore/aft. Please see Figure 9. Each wing attaches at the front and rear spar tooling plus a cradle-type post under rib 7. All of those posts have independent up/down (waterline) movement. Critical to the aircraft performance, there are three additional measurements at each wing tip to verify the correct sweep, angle of attack, and dihedral of the aircraft. Those measurements are described below.

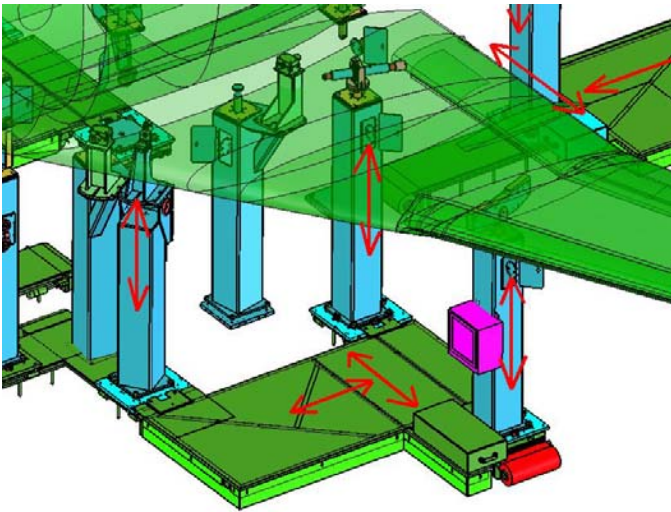

Figure 9. Wing axes of motion detail

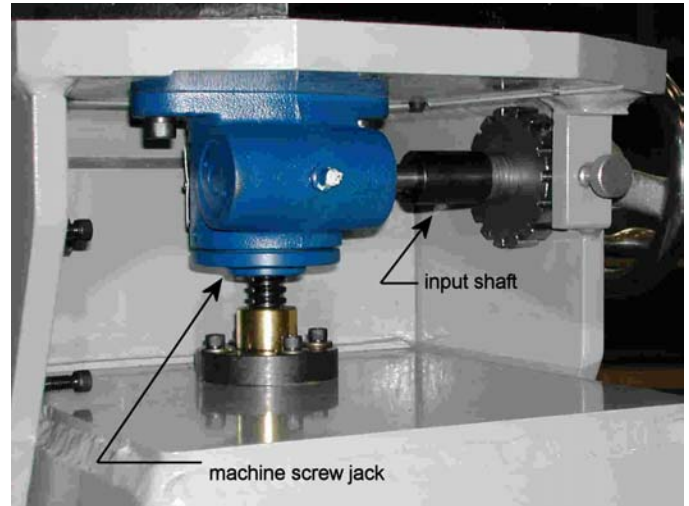

Figure 11. Wing front spar post vertical axis

All positional axes and the 6 wing tip axis have their joining positions accurately measured with a linear potentiometer. See Figure 10. The model used is ETI Systems LCP12-50S-1KΩ. See the Position Measurement section below for more details.

#### Axes movement – horizontal and raft

The wings, the fore fuselage, and the aft fuselage subassemblies move relative to the CTS. The moving subassemblies are loaded by crane onto the rafts grossly 850 mm (33.5 inch) away from the center fuselage. See Figure 12.



Figure 12. Fore fuselage loaded 0.85m from CTS

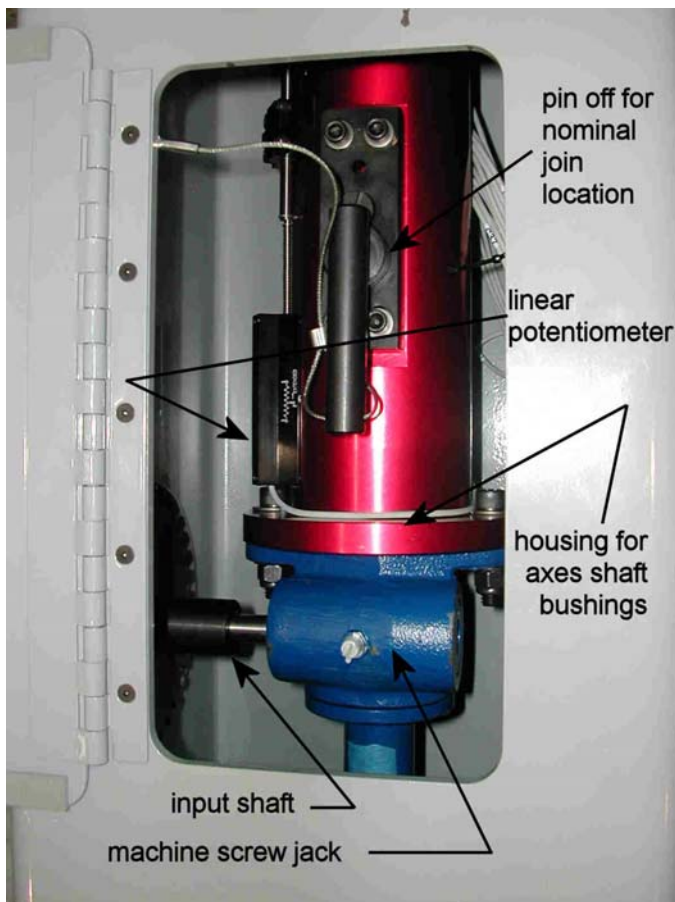

Figure 10. Typical vertical axis within a post

#### Axes movement - vertical

The 19 positional axes are manually or drill motor actuated using industrial, machine screw jacks. See Figures 10 and 11 for examples of vertical jacks on posts. The machine screw jacks, generate 8900 N (2000 pound force) maximum, with low backlash, 0.25 mm output per input turn (100 turns per 1.00 inch.) The jacks are Nook brand, #1AB-MSJ-U20:1.

An T-handle pin is removed, and the operators manually push each raft towards the Center Section on low friction, linear roller bearings. The pin is reinserted so that final motion towards the Center Section is accurately controlled by machine screw jacks. Horizontal motion is provided with similar jacks as used on all the vertical axes. The only difference between any of the jacks is the stroke length.

Jack screws provide precision movement of the last 190 mm (7.5 inch) of the wings inboard/outboard relative to the center fuselage. Similarly, a jack screw provides precision movement of the last 190 mm (7.5 inch) of the forward fuselage subassembly fore/aft relative to the center fuselage. The aft fuselage assembly has 270 mm

(10.5 inch) of jack screw motion fore/aft to the Center Section. See Figures 13, 14, and 15.

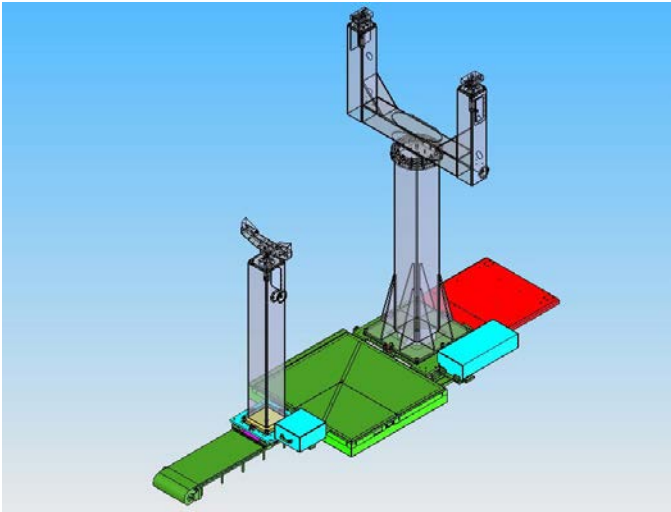

Figure 13. Aft fuselage raft overall

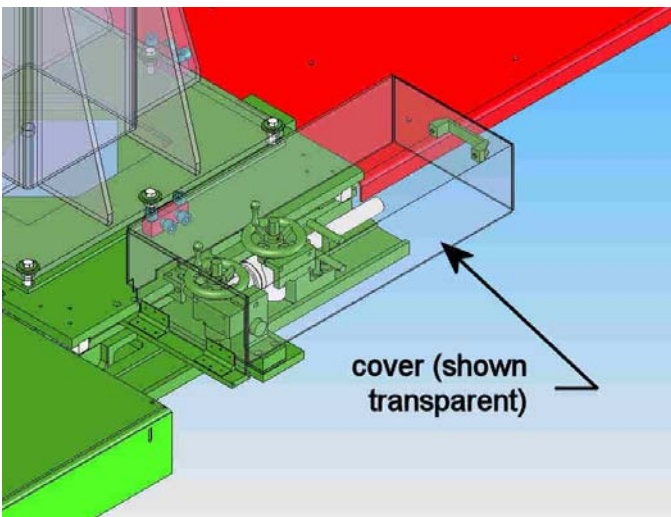

Figure 14. Aft fuselage raft drive assembly isometric view

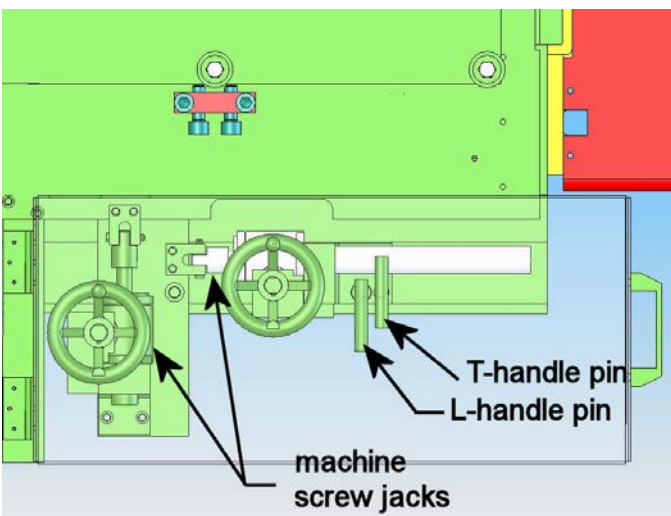

Figure 15. Aft fuselage raft drive assembly plan view

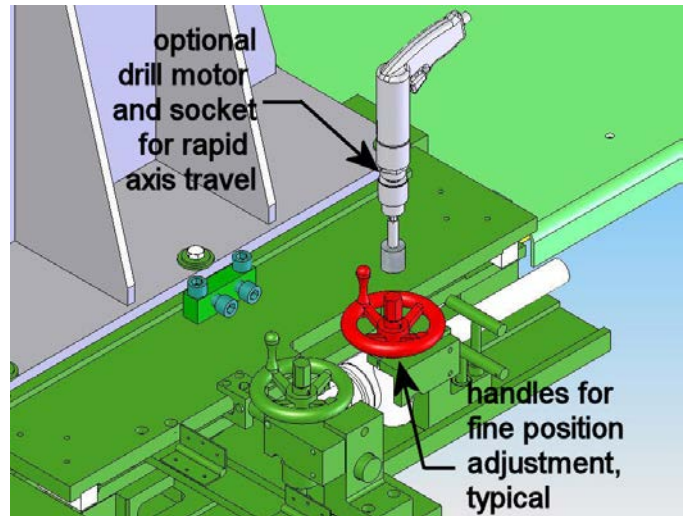

Figure 16. Hand crank or drill motor drive for axis of motion

There are several mechanical pin-off locations. Figures 15, 16, and 17 show two pins for establishing the position of this axis. The T-handle clamping pin locks the rolling portion of (raft) axis after the axis has been pushed 0.85m towards the CTS. The jacking screw then controls the raft axis. An L-handle pin is used to either lock the screw portion of the axis in the retracted position or a known, nominal joint position. (The pins are Carr Lane CL-4-CP and CL-13-LP.)

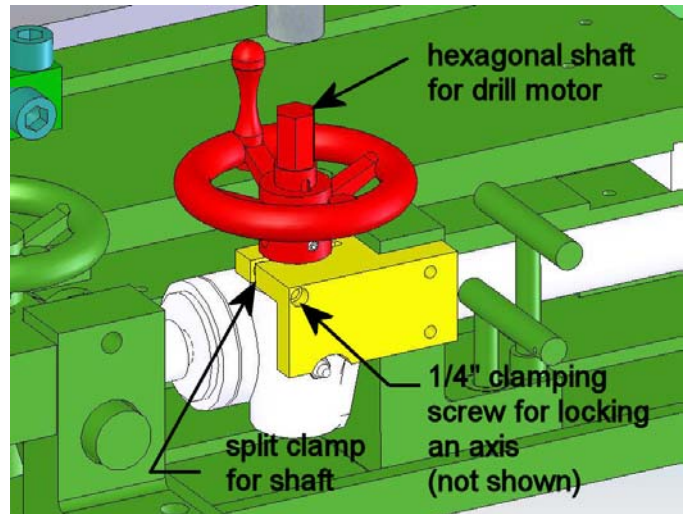

Figure 17. Shaft clamp to fix axis position.

Figure 17 shows a typical shaft clamp that is used for fixing the input (and hence the output) of the jacking screw. A 1/4" (6.35mm) screw tightens a split collar around the 1/2 inch (12.7mm) input shaft of the jack screw. With a 20:1 ratio, the axis cannot be back-driven when the collar is tightened.

The raft horizontal axes have their joining positions accurately measured with the same linear potentiometer used throughout the joint cell. The shaft of each linear pot contacts a stop within +/- 25 mm (1.0 inch) of the final joint position. There is no measurement of the gross 0.85m (33.5 inch) movement to get the fuselage or wings towards the Center Section.

## G150 Join Cell Airframe fixtures and tooling

On top of each post, various indexes, pins, and/or supports connect to the airframe. The Center Section is connected through the CTS as shown in Figures 18 - 20 below. See Figures 4 and 5 (above) for photographs of the Center Section mounting.

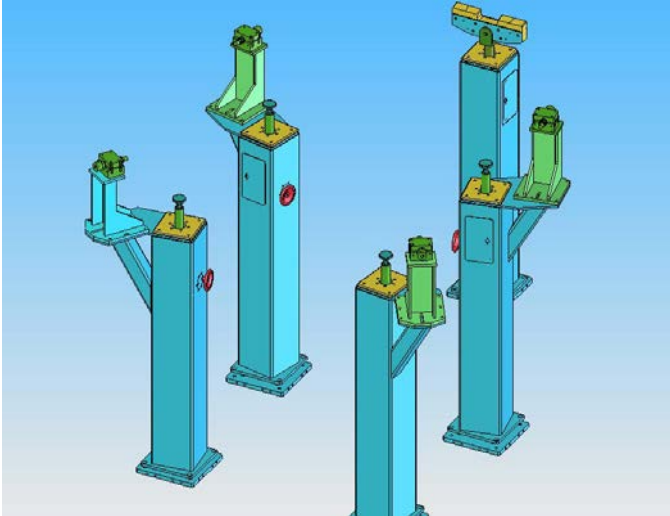

Figure 18 CTS index and post models

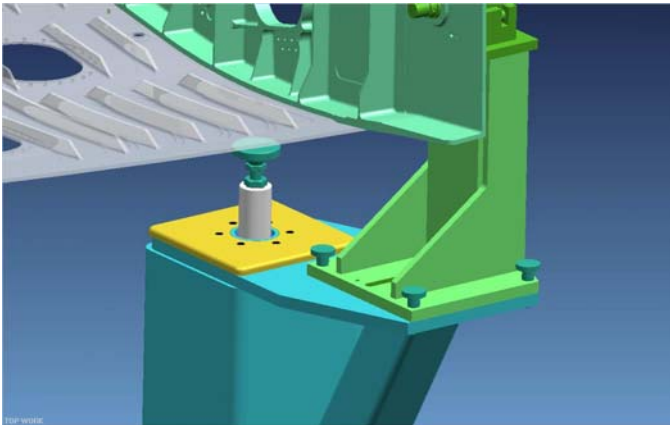

Figure 19 CTS index models front spar



Figure 20 CTS index and post photographs

The forward fuselage has two supporting posts. The forward fuselage section is manipulated fore/aft, up and down. Please see earlier Figure 7 for the axes directions.

The diagonal drag brace for the nose landing gear is held fixed by the pins shown in Figures 21 and 22. This fixed height of this post defines the aircraft waterline or Z location in the Join Cell.

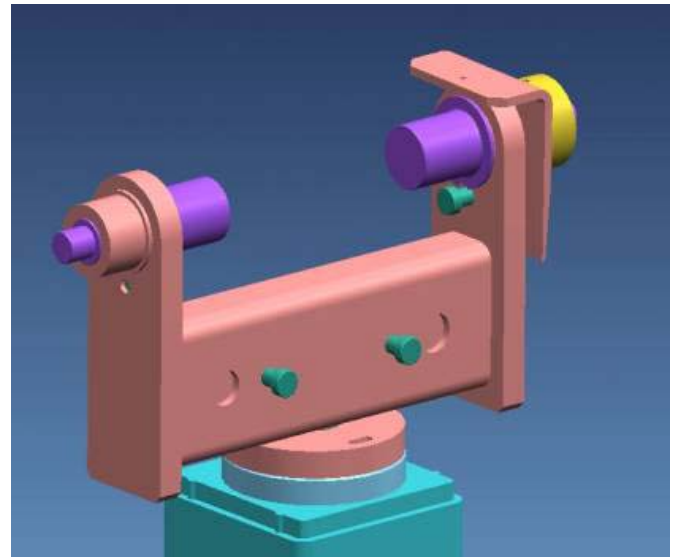

Figure 21. Drag brace for nose gear interface – model

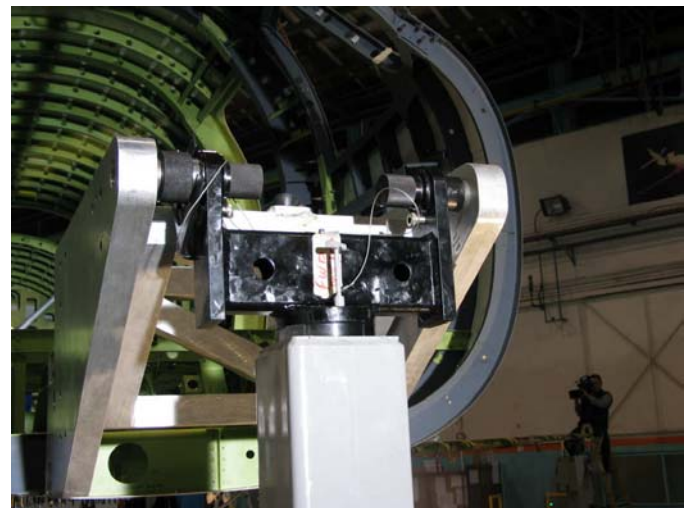

Figure 22. Drag brace for nose gear interface – photograph

A cradle supports the rear most part of the forward fuselage giving Z, X (inboard/outboard) and roll positional control. The two independent vertical axes allow a slight roll of the forward fuselage where it attaches to the center fuselage. See Figures 23 and 24 for the model and actual hardware of the cradle that carries the aft end of the forward fuselage.

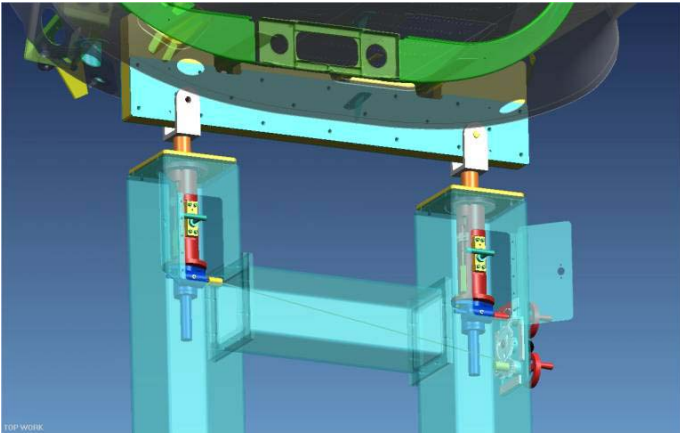

Figure 23.. Fore fuselage rear cradle model.

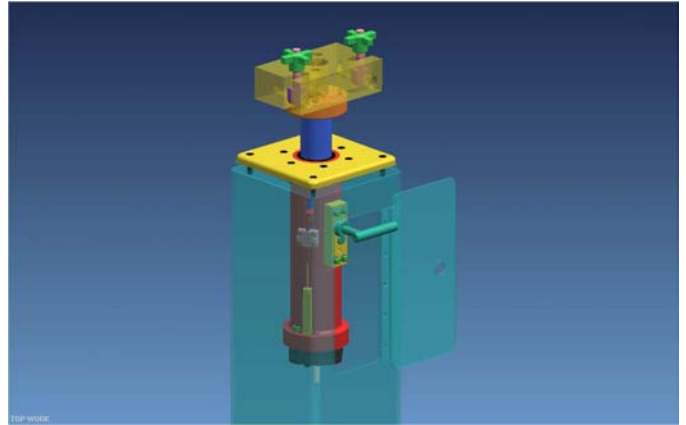

Figure 26. Aft engine interface model



Figure 24. Fore fuselage rear cradle photograph.



Figure 27. Aft fuse and engine interface photograph

The aft fuselage is manipulated fore/aft. Please see Figure 8, above, for the axes of motion. A post and cradle under the front of the aft fuselage manipulates both inboard/outboard and up/down (water line.) An independent post attached at the engine mounts at the rear of the aft fuselage manipulates the engine mounts both inboard/outboard and up/down (water line.) A passive bearing allows engine mount rotation in the horizontal plane parallel to the rear fuselage. See Figures 25 – 27 below for models and a photograph of the aft fuselage attachment within the Join Cell

Each wing mounts to three posts with axes of motions indicated in Figure 9 above. Each wing attaches at the front and rear spar tooling plus a cradle-type post under rib 7, see Figures 28 – 32. Figure 29 shows a model of the front spar index on top of its post. Figure 32 shows a photograph of the same.

Within each wing, Figure 30 shows the interface to the main landing gear bushings. A cradle supports the lower wing skin at the outer mold line underneath rib 7. See Figures 28, 31, and 38

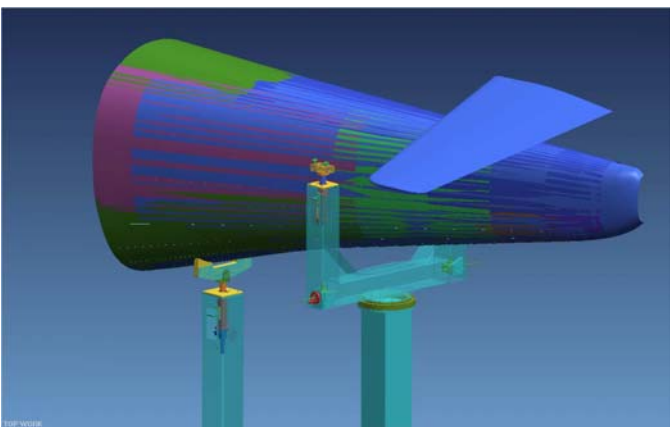

Figure 25. Aft fuselage post and index model

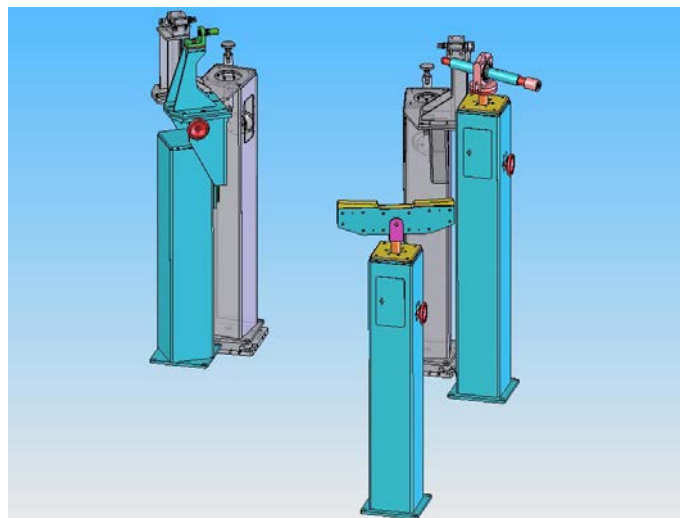

Figure 28. Inboard wing post and index model

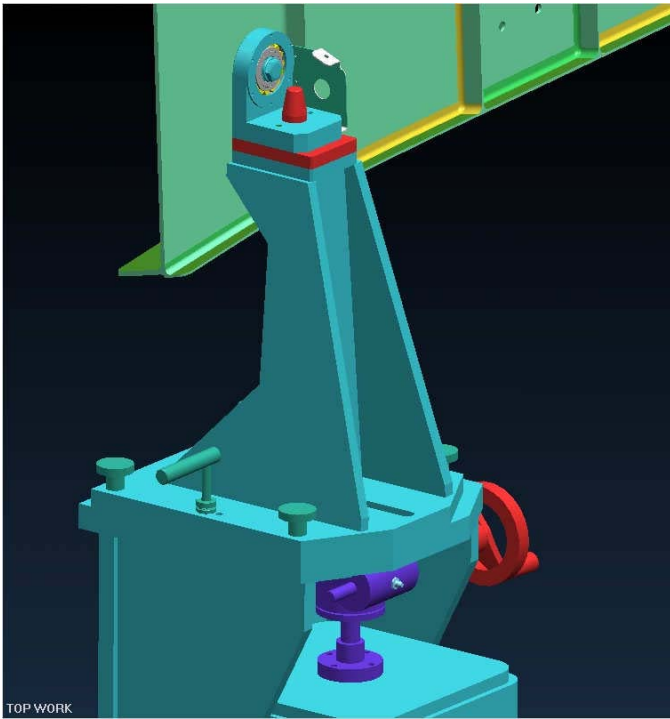

Figure 29. Wing front spar index model

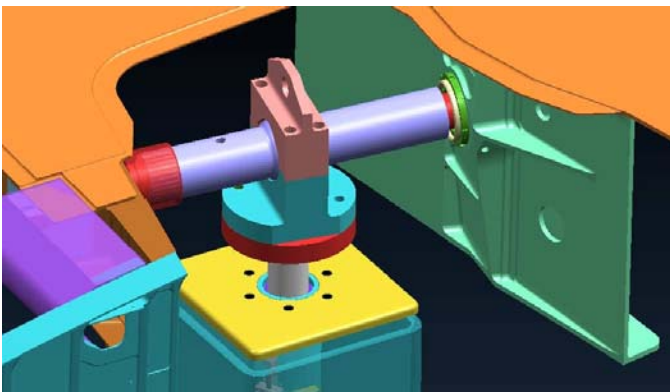

Figure 30. Wing main landing gear interface model



Figure 31. Wing post and interface photograph



Figure 32. Wing front spar and CTS interface photo

Critical to the aircraft performance, there are three additional measurements at each wing tip to verify the correct sweep, angle of attack, and dihedral of the aircraft. Those measurements are made from stationary, floor-mounted monuments as shown in Figures 33 - 36 below.

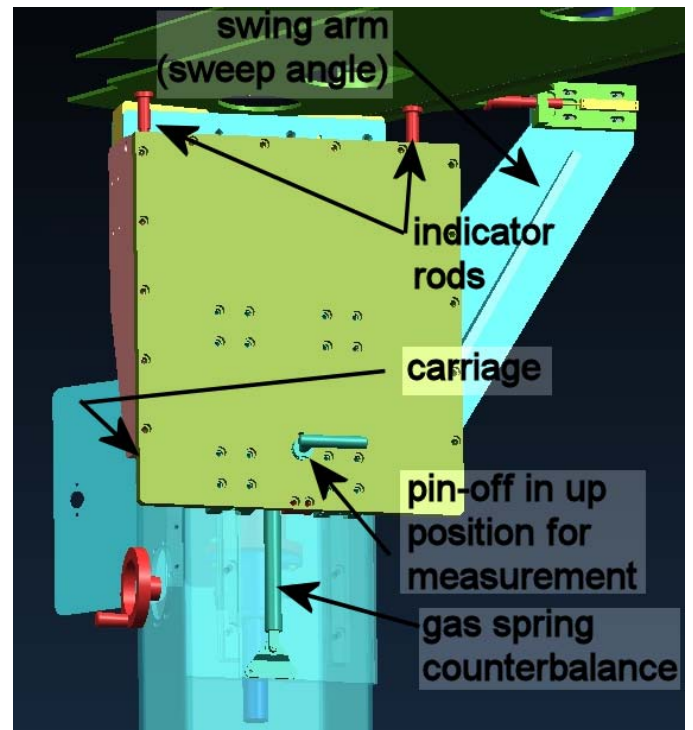

Figure 33. Wing angle of attack measurement model

Figures 33 - 35 illustrate how the angle of attack measurement is made at each wing tip. While wing loading, operators crank up a plastic cradle so the wing tip rests on or above the cradle. After the wing to CTS joint is in position, operators push a linear-rail mounted carriage is upward to a known, pin-off position. A gas spring counterbalance takes the most of the carriage weight. This carriage contains 2 linear potentiometers that measure the angle of attack at each wing tip. The linear potentiometers are connected to spring-extended, indicator rods as shown in Figures 33 - 35. The cradle



is lowered so it does not touch the wing during the actual angle of attack measurement. As shown in Figure 35, the indicator rods push against temporary rivets on the underside of the wing skin.

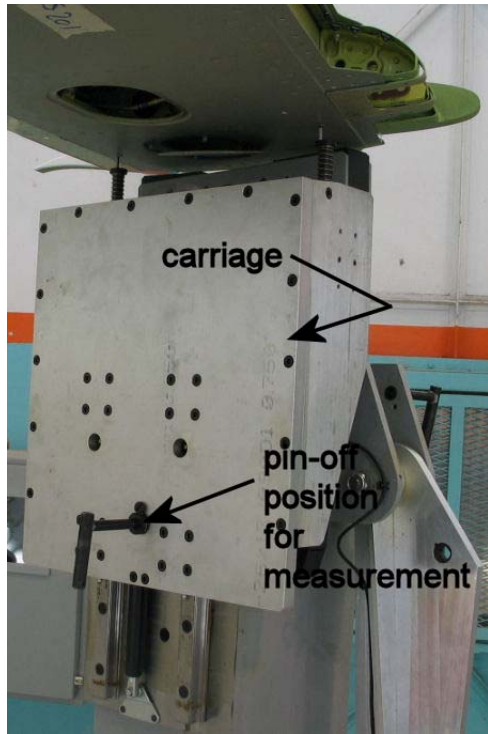

Figure 34. Wing angle of attack measurement photograph 1.

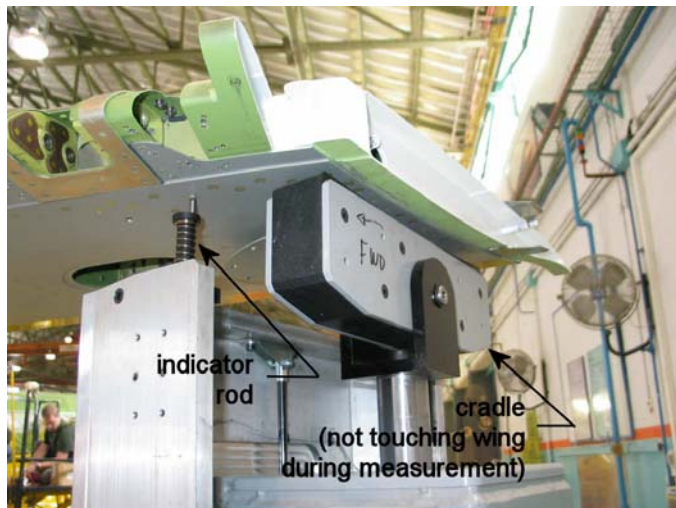

Figure 35. Wing angle of attack measurement photograph 2.

The wing sweep angles are measured at each wing tip. On the same post as the angle of attack measurement, operators move a swing arm into position. See Figures 33 and 36. Operators swing the arm up and locate it with at pinned position for the sweep measurement. A linear potentiometer, attached to a spring-loaded slide, bumps against a datum surface on the wing front spar. As with the angle of attack measurements, operators monitor and record data from the sweep angle

measurements at any or multiple times during the join process.

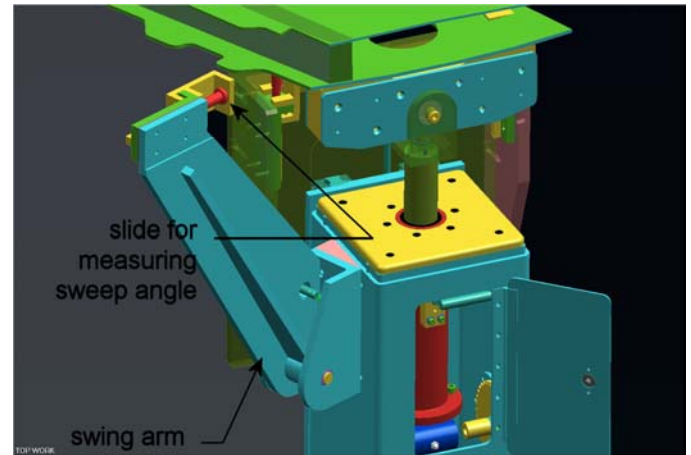

Figure 36. Wing sweep angle measurement model

#### POSITION MEASUREMENT AND DATA ACQUISITION SYSTEM

All 19 positional axes and the 6 wing tip axes have their joining positions accurately measured with a linear potentiometer. See one example in Figure 10. The model used is ETI Systems LCP12-50S-1KΩ. This linear pot has micron accuracy over its 50 mm (2.0 inch) of stroke. With the mechanical linkages considered, axes positions are measured within +/- 0.025mm (+/- 0.001 inch.)

#### Touch screen video displays.

All 25 linear potentiometers feed data to a Siemens PLC that oversees the join cell. Output from the PLC drives two, touch-screen, video displays for the mechanics joining the G150. These two screens are located on posts on the wing rafts, see Figures 37 and 38



Figure 37. Screen display location in the join cell, looking outboard



Figure 38. Screen display location in the join cell, looking inboard

The aircraft mechanic sees an intuitive graphical user interface (GUI) that is easy to use. See Figure 39 below.



Figure 39. Initial screen of the GUI.

Each actuator needs to be within the tolerance on the screen. If an axis is out of tolerance a part of the screen flashes red. Flashing red is an indication to the operator. See Figures 40 and 41.

In addition to the normally displayed operator screens, there are (password protected) setup, maintenance, and data archiving screens.

#### Data archiving

Operators can store all 25 axes positions whenever they need to by accessing the screen shown below in Figure 42.

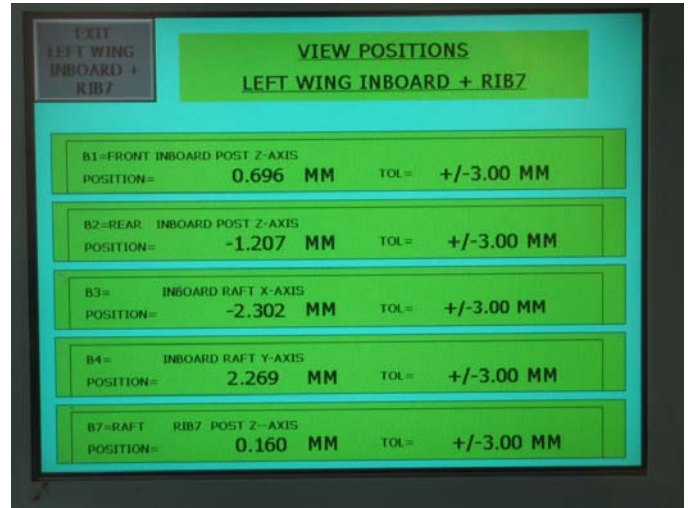

Figure 40. Typical touch screen display, close-up



Figure 41. Touch screen display with red warnings

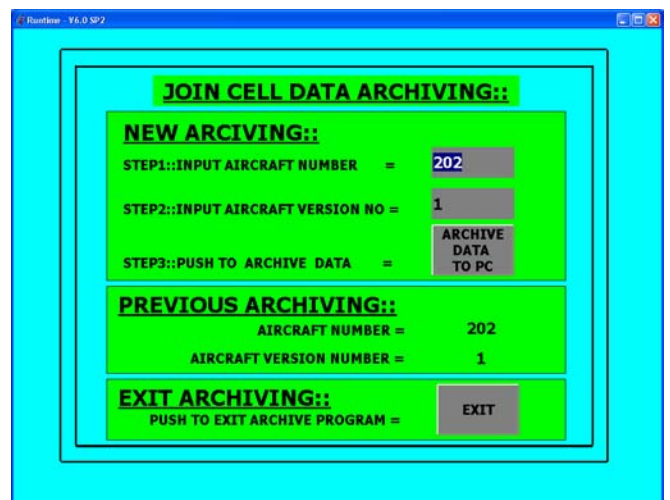

Figure 42. Screen used to store data from the join cell.

A data set is always stored after the final join of each aircraft sequence number. Data is stored in a .csv or spreadsheet format. IAI monitors historical trending of the final join positions. An example of the wing dihedral measurement, the difference between the angles of attacks between the wings, is shown below in Figure 48

## BENEFICIAL FEATURES OF THE JOIN CELL

### Open Post-type Architecture

One of the main features of the G150 Join Cell is its relatively “open” post construction. This allows mechanics access to the joints for drilling and fastening. IAI had prior experience with the final join cell for the G200 (Galaxy) aircraft. With the G200, a trussed box structure supports fuselage components. While functional, access is very limited near the final splices. See Figures 43 and 44 below. Contrast that to the G150 cells, Figures 45 and 46 below.



Figure 43. G200 Join Cell, side view.



Figure 44. G200 Join Cell, right wing support and scaffolding.



Figure 45. G150 Join Cell, front view



Figure 46. G150 Join Cell, right wing support and scaffolding.

### Easy to move subassemblies for drilling, deburring, final fastening

A single operator can move the forward fuselage, aft fuselage, and wing subassemblies easily and intuitively. This includes the ability to move the subassemblies 0.85 meter (33.5 inch) away from the Center Section for cleaning and deburring. Please see Figure 12 above and Figure 47 below. Operators do not need special knowledge of CNC controls when they move the subassemblies back to prior exact positions for the final fastening.



Figure 47. Aft Fuselage Loaded 0.85 m from CTS

#### Accurate and repeatable aircraft and wing positioning

As shown in the display of Figure 40 above, operators can easily manually position all axes within +/- 0.025mm (+/-0.001 inch.) These touch screen displays have an intuitive graphical user interface that is easy for aircraft mechanics to use, see Figure 39 – 42 above. The linear potentiometers and machine screw jacks enable the highly accurate and inexpensive axes. The linear pot has micron accuracy over its 50 mm (2.0 inch) of stroke. The low backlash machine screw jacks move the aircraft subassemblies 0.25 mm per input turn (100 turns per 1.00 inch.) Overall accuracy of each axes is only limited by the mechanical connections between the aircraft parts and the linear potentiometer.

#### Non-evasive wing measurement and data acquisition.

As discussed earlier, critical measurements are performed at each wing tip of the angle of attack and sweep angle. Those six measurements and all 19 motion axes positions can be recorded any time during the join process. Any mechanic can navigate through the GUI starting with the screen shown in Figure 39 above. And then they can record data with the acquisition screen in Figure 42 above.

Overall this allows IAI to actively monitor and control the quality of the G150 final join. An example of the wing tip dihedral is shown in the Figure 48.

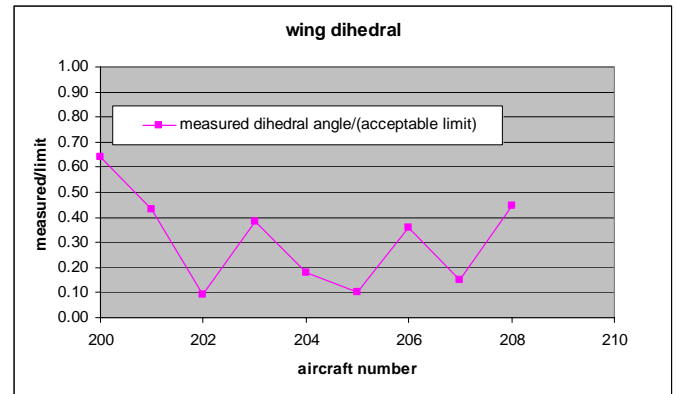

Figure 48. Trend of historical data from the join cell

## CONCLUSION

The production version of the concept for an, open, post-supported, final fuselage join cell has proven to be simple to use by aircraft mechanics. The Join Cell provides open access, benefiting the final aircraft joining for the G150 business jet. Physical repeatability coupled with electronic data recording contribute to the quality of the final G150 airframes.



Figure 49. G150 Airframe after joining

## ACKNOWLEDGMENTS

The authors thank Israel Aircraft Industries for the photographs and information contained in this paper. The authors acknowledge significant engineering work by Ezra Gut of IAI and Craig Selbeck, Zvika Yaniv, Keith Zealy at Electroimpact for the Join Cell.

## CONTACT

Samuel O. Smith is a Project Engineer with Electroimpact in Mukilteo, WA. Telephone 425-609-4892, [sams@electroimpact.com](mailto:sams@electroimpact.com) Dr. Peter Zieve is the founder and President of Electroimpact. Visit [www.electroimpact.com](http://www.electroimpact.com). Michael Gurievsky is a Manufacturing Engineering Manager with Israel Aircraft Industries in Tel Aviv, telephone 972-3-935-3372, [mgurievsky@iai.co.il](mailto:mgurievsky@iai.co.il)

## **DEFINITIONS, ACRONYMS, ABBREVIATIONS**

**CTS:** Carry Through Section. The structural center wing box.

**GUI:** graphical user interface. The display the operator sees on the computer monitor.

**IAI:** Israel Aircraft Industries

**index:** A mounting position that establishes the exact location of an aircraft surface. For instance, the nose landing gear index is a bar extending through the bore of mounting bushings for the nose landing gear. A shoulder on the bar indexes one side of the gear bushing in port/starboard direction.

**post:** Any of the rectangular steel columns extending up from the rafts with the aircraft indexes on top.

**raft:** Any of four tooling carriages that support the posts and move them in the horizontal plane. The wing rafts, for example, act as an industrial X-Y positioning table for the wings.